

PHASE	QTY.
1	1
GRID LOCATION	
1RA1/1 TH1-C***	

ALL WELDS TO BE 6CFW U.N.O (AS/NZ 1554)  
 REMOVE ALL BURRS BEFORE PAINTING/GALVANISING  
 MARK BEAM SIDE ON CONNECTIONS PLATES MARKED <  
 STAMP/MARK BEAMS ACCORDINGLY

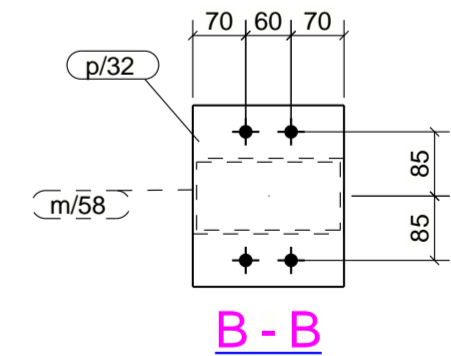
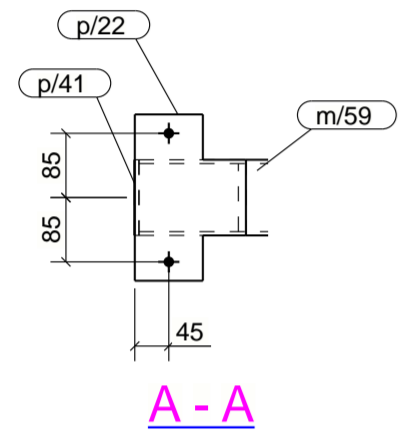
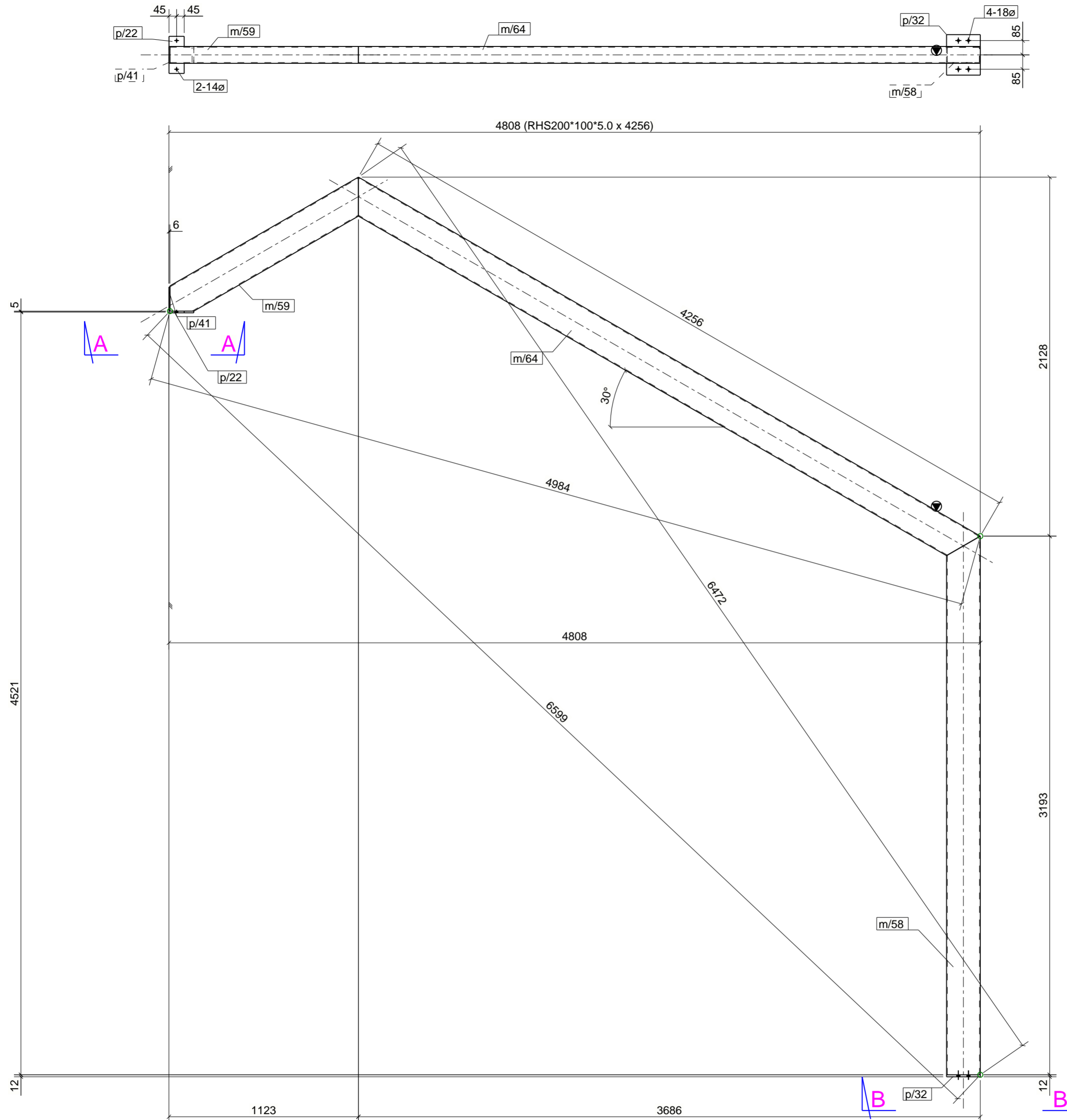

**1 FEATURE FRAME[S] REQUIRED MK 1RA1/1**  
**Finish - PRIME PAINTED**

MATERIAL LIST						
ITEM	No.OFF	SECTION	LENGTH	GRADE	WEIGHT(kg)	AREA(m <sup>2</sup> )
m/58	1	RHS200*100*5.0	3193	C350L0	70.4	1.8
m/59	1	RHS200*100*5.0	1364	C350L0	30.1	0.8
m/64	1	RHS200*100*5.0	4256	C350L0	93.9	2.5
p/22	1	PLT10*147	220	250	2.0	0.1
p/32	1	FL12*200	240	250	4.5	0.1
p/41	1	FL6*100	143	250	0.7	0.0
TOTAL:					201.6	5.3

- Notes:
- ALL WELDS TO BE 6CFW U.N.O
  - MARK ASSEMBLIES AS SHOWN ON DRAWINGS
  - MARK BEAM SIDE ON CLEATS WHERE INDICATED
  - MARK NORTH SIDE AS INDICATED
  - QUESTIONS - CALL ANDREW ON 0414 482 613

Rev	By	Date	Description
1	MN	08/03/2023	ISSUE FOR FABRICATION

MARKED	TACKED	CHECKED	FABRICATED
DATE:			
INITIALS:			

<b>CUSTOMER NAME</b>		Develle Structures 14/1 Independent way Ravenhall, VIC, 3023 Contact: Andrew Cimbaljevic Mobile: 0414 482 613	
<b>ADDRESS</b>		Develle Structures	
<b>SUBURB</b>		Drawn By: AC	
<b>FEATURE FRAME</b>		Checked By: MN	
Scale: 1:20		Approved By:	
Project No: 2SMITH		Qty: 1	
Assembly No: 1RA1/1		Size: A2	
Sheet No: 1		Rev: 1	